

NETZSCH

NETZSCH Original-Accessories Process Monitoring and Optional Extras

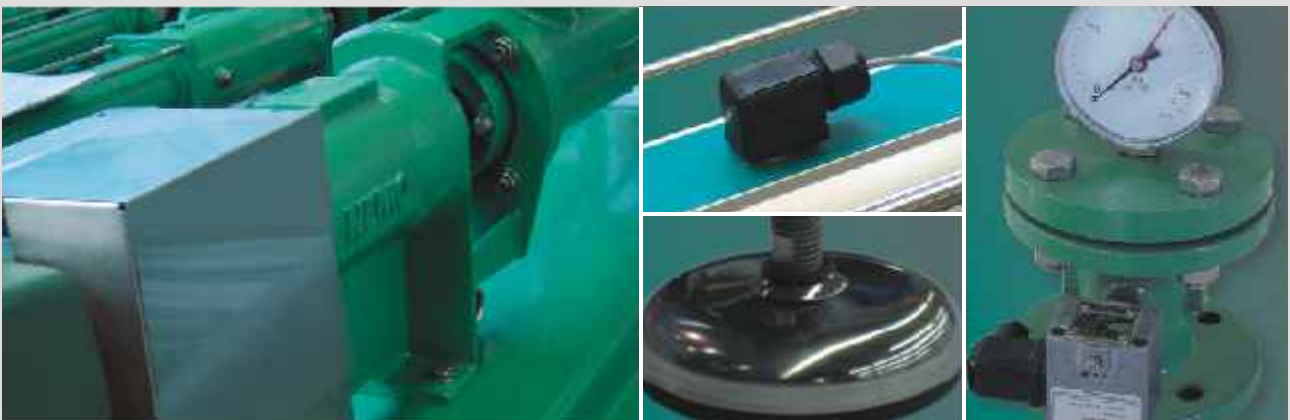

The heart of your process. ■

Dry Running Protection

NETZSCH dry running and over-/underpressure protection devices avoid thermal destruction of stators and protect the pump and accessory equipment.

Dry Running Protection for NEMOLAST® Stators

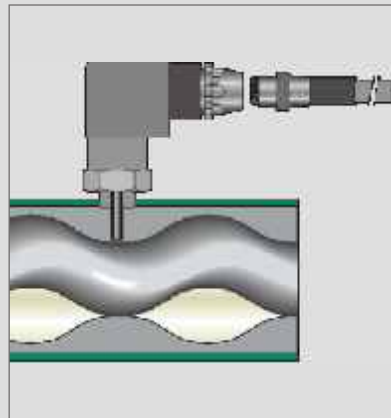

The dry running protection units (STP2A, STP2D) operate by monitoring the temperature between rotor and stator during normal operation. Should the operating temperature rise over a predetermined set point due to an increase in friction caused by dry running the unit will shut down the pump, thus preventing any damage to stator and rotor. The controller can be set for two different switch temperatures: the first set temperature is used for the normally pumped product, the second set temperature can be used for a different medium temperature, for example for a cleaning process.

Flow Sensing Unit for Solid Stators



The flow sensing unit is used to protect a progressing cavity pump fitted with a solid stator against dry running. The unit senses the flow in the suction or discharge pipework. Should the flow drop below a predetermined level, indicating a dry running situation the unit will shut down the pump, thus preventing any damage.

Speed Monitoring Device

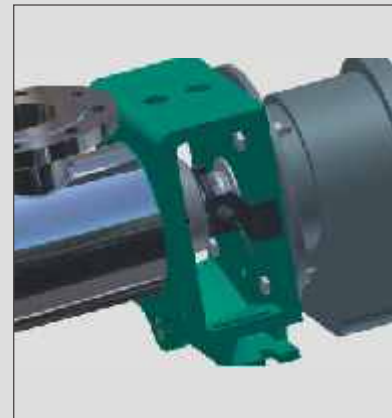

Where it is necessary, for process reasons, to monitor the rotational speed of a pump we offer impulse switches mounted to drive unit. These units can be fitted to both block construction and bearing housing pump designs. The shaft can be fitted with one or more contacts to provide the required number of impulses per revolution. The units are supplied robustly mounted to the pumps.

Over-/Underpressure Protection

NETZSCH over-/underpressure protection devices protect the pump and accessory equipment from unsuitable pressures, therefore increasing the operating reliability of the pump and minimising downtime.

Diaphragm Pressure Gauge G3/4 Inch Connection



The pressure gauge displays the operating pressure. Gauge is isolated from the process fluid by a stainless steel diaphragm. Shut down of the pump when the maximum allowable pressure is exceeded with adjustable pressure setting. Suitable for low up to medium viscosities.

Diaphragm Pressure Gauge



Operation similar to the G3/4 inch unit, with larger flanged connection DN50 PN40 or 2" ANSI B16,5 300 lbs, suitable for highly viscous and clogging fluids.

Pressure Control Device DTSL 3



Display of operating pressure by a bourdon gauge. Gauge is isolated from the process fluid by an elastomer diaphragm. Shut down of the pump when the maximum allowable pressure is exceeded with adjustable pressure setting. Also available with a differential pressure on/off switch.

Multi-Function Pressure Instrument

In addition to a display indicating the current operating pressure of the pump, with this simple to install unit, it is also possible to set alarm points for over pressure and to initiate an emergency pump shut-down.

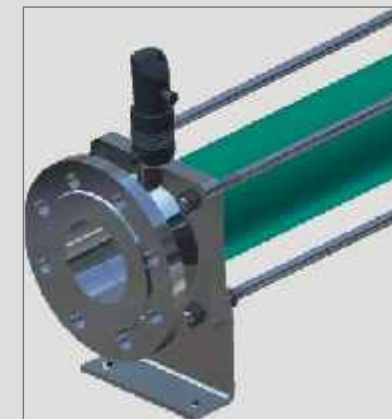

Seal Support Systems Tools and Optional Extras



Seal Support Systems

To ensure the problem free operation of a shaft seal system it is often necessary to install a quench, flushing or pressurised barrier system so that the seal operates in ideal conditions.

Quench Pot



A quench pot is necessary when a shaft seal needs to be operated with a quench, but it is not required that the seal has a permanent flushing flow. So that dry running of the seal or crystallisation of the pumped product can be prevented we recommend the installation of a quench pot.

Permanent Lubricator

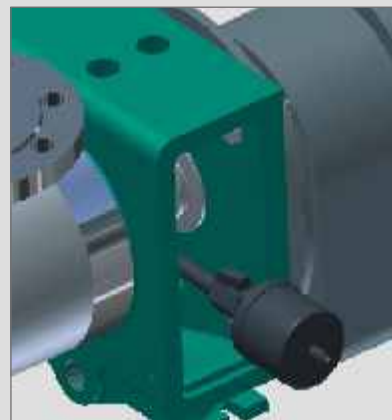

The Permanent Lubricator is used support the sealing function of shaft seal. This can be used for packed glands as well as mechanical seals fitted with an additional quench ring. The lubricator provides a constant flow of grease into the quench ring or lantern of the seal against the pressure of a spring within the unit. Should the pump not be run for any period of time the lubricator can be isolated with a valve. The unit is a robust metal construction and can be refilled.

Pressurised Flushing for double Mechanical Seal Systems

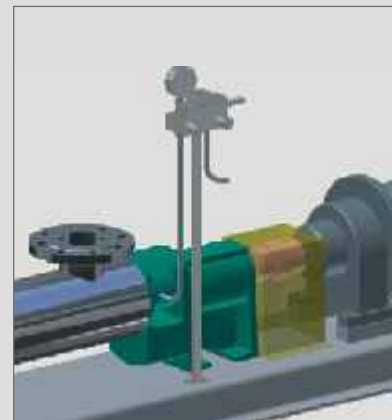

When using a back to back mechanical seal it is necessary to provide a seal support system. For such a seal system to operate correctly a positive pressure is required between the individual seals. The seal support system should have an operating pressure a minimum of 2 bar above the working pressure of the process side. Furthermore it is necessary to be able to control the flow of flush medium in the seal chamber. To facilitate such a system we offer a complete support system, with the intermediate piping, conveniently mounted on the pump baseplate.

Tools and Optional Extras

For simple maintenance and problem free operation many helpful tools and accessories are available.

Gear Joint Filling Unit

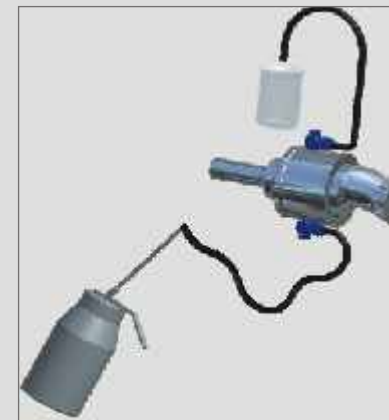

For the correct operation of a Gear Joint and to ensure a long service life it is important that the joint is correctly filled with lubricating oil. To assist the quick and complete filling of the joint we offer a filling unit complete with oil container, pump unit and hoses.

Ring Dosing Nozzle



For the transportation of high viscosity media we recommend the installation of our ring dosing nozzle. The nozzle fits directly to the discharge connection of the pump and allows the injection of a boundary layer lubricant. Depending on the lubricant used the pressure loss in the discharge pipework can be reduced by up to 70% in comparison to operating the system without any lubricant injection. By operating this system both the investment and operating costs are significantly reduced.

Chemical Anchor



To fix pump baseplates to the ground securely we recommend the use of our chemical bolt system. A two component adhesive is used to secure the bolt. After a short curing time the bolts is fixed into the ground allowing connection of the pipework.

Stator Removal Tool

This tool is useful to assist with the removal of stators from pumps. For pump sizes up to NM 045 we recommend the use of our strap wrench. For the pump sizes of NM 053 and above we recommend our chain wrench.

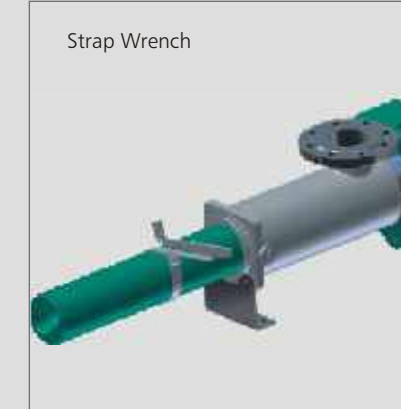

Protection Units Trolley Assemblies

Protection Units

In all production areas within the food, pharmaceutical and cosmetic industries a range of mobile and fixed mounting options are available to ensure hygiene of the highest standard.

Machine Feet

Often by the installation of a pump together with a baseplate it is necessary to ensure that the floor surface is not damaged. Therefore we offer machine feet which are mounted directly on the baseplate.



Advantages

- No crevices or hollow areas where bacteria can accumulate, hygienic pump installation
- Easy cleaning of the floor underneath the pump
- No damage to floor tiles as with fixed anchoring
- Threaded adjustment allows easy levelling of the pump

Covers for Drive Motors

For pumps that require an additional level of protection we offer a range of stainless steel covers for the drive.

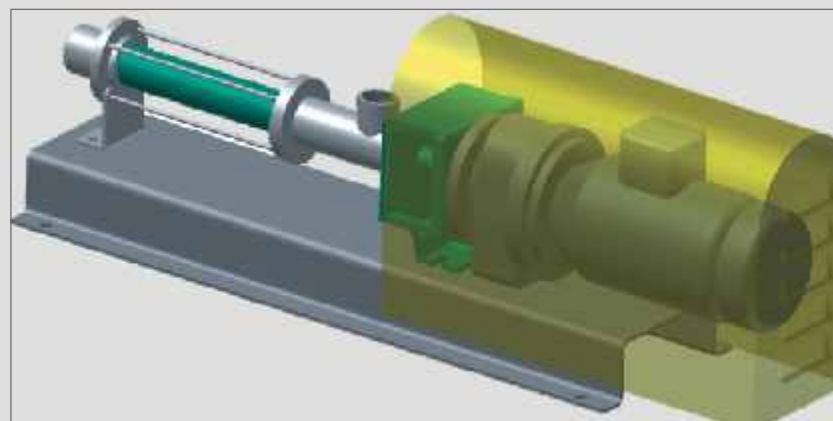

Wide Range of Applications

- Especially suitable for units operated in a wet environment providing protection against hoses and condensation for overhead equipment
- Protection for hot drive units
- Weather protection for drives installed in an open air environment
- Covering of the drive for optical reasons

Advantages

- Completely covered drive and lantern with ventilation slots
- Guarding for the drive shaft
- No level surfaces prevent the collection of water
- Stainless Steel Construction

Trolley Assemblies

For when it is necessary to be able to easily move a pump between operating areas we offer trolley assemblies. The trolleys are a twin axle design with one set of steerable wheels and come complete with a handle.

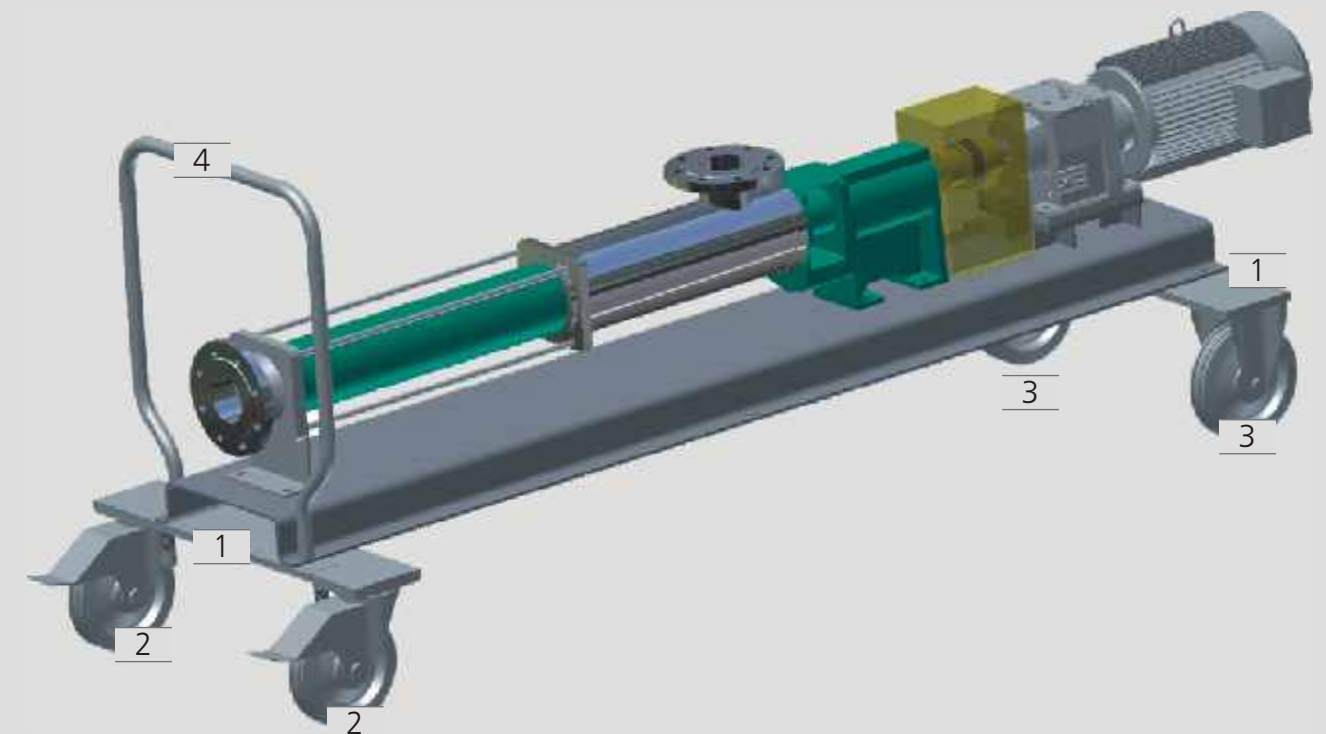

1 Wheel Mounting Plates

2 Steerable Wheels

3 Fixed Wheels

4 Pulling Handle in Stainless Steel

NETZSCH

www.netzsch.com

NETZSCH Mohnopumpen GmbH
Geretsrieder Straße 1
84478 Waldkraiburg
Deutschland / Germany
Phone: +49 8638 63-0
Fax: +49 8638 67981

E-mail: info.nmp@netzsch.com
www.netzsch.com
